

## Description

This test measures the accuracy of the current sense amplifier circuit of the X3100. In the test, a known current is applied through a sense resistor to generate a voltage between the current sense inputs of the X3100. The analog output voltage of the X3100 is measured. This value (adjusted by the amplifier gain) is compared to the input voltage. The collected data includes the values from five devices from three different lots. The data also includes tests at 0°C, 25°C and 50°C and at each gain setting.

## Test Setup

This test applied a current across the sense resistor to develop a voltage ranging from approximately 200uV to 100mV. The current source was forced through a 20.37Ω resistor that connected across the VCS1 and VCS2 pins. The 20.37Ω resistor was chosen to improve the accuracy of the resistance measurement. In an actual battery pack, a resistor in the range of 25mΩ to 50mΩ would be used. At 200uV, the minimum current measured would be 4 - 8mA. In this current measurement test, the current was forced in specific discrete increments, such as 10uA, 20uA, etc. However, since the resistor was 20.37Ωs, the applied voltage is represented in less recognizable increments.

For each applied voltage the output was recorded, first in one direction, then in the other. This involves the changing of the analog multiplexer setting in the X3100. While this procedure cancels the majority of the offset, as the data shows, a small offset remained even after this procedure. In gathering the data with this test, the output was sampled 20 times for each setting. The high and low values were discarded and the remaining samples were averaged. This procedure was used to reduce the effect of external noise on the test environment.

## Results

The data for this test is available in raw form in an Excel spreadsheet. This spreadsheet includes data for each device, data for each lot, and data for all devices. Each set of data includes results for the three temperature settings and the four gain settings. The data was copied to other files for the purposes of generating graphs.

For the result summaries there are raw error measurements and error measurements assuming both an offset correction and a gain correction. The offset correction was derived by taking the average offset over all devices, temperatures and lots. This offset value was then added to each of the measured outputs at each gain. After this correction, the gain was computed for each input voltage. These gain values were averaged over the devices, temperature and lot. This average value was then factored into the results.

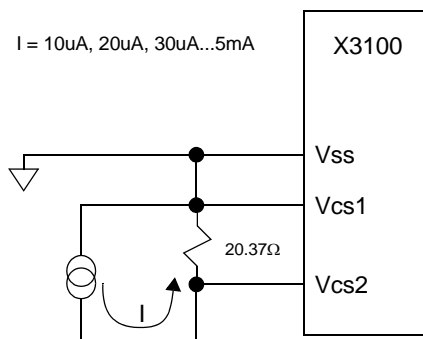

FIGURE 1. CURRENT SENSE MEASUREMENT

On the following charts, errors are calculated as follows:

Raw error:

$$Raw = \frac{O - I}{G}$$

Average error:

$$Avg = \frac{avgO - I}{G}$$

Average error after offset and gain adjust:

$$AvgOGadj = \frac{avgO - avgoff - I}{avgG}$$

Worst case error at 0°C, after offset and gain adjust:

$$StdOGadj(0) = \frac{avgO(0) + 3 \times std(0) - I}{avgG}$$

Worst case error at 50°C, after offset and gain adjust:

$$StdOGadj(50) = \frac{avgO(50) - 3 \times std(50) - I}{avgG}$$

Where: O = Output

I = Input

G = Gain

avg = Average

std = Standard Deviation

off = offset

OG = Offset/Gain

(x) = at x degrees C

### Overall Performance

The following set of graphs shows the performance of the X3100 over temperature and across three lots of five devices. The graphs will show the basic input/output curve, raw error, and error after correction for offset and gain.

The below data shows that the error at the x10 gain is the lowest. Using a 20mΩ current sense resistor, and considering 3 standard deviations from the worst case temperature (over 3 manufacturing lots), the X3100 output is accurate to less than 1.4% at 300mA of load current and above. At a gain of 25, the X3100 has less than 5% error at a load current of 50mA. This error declines at higher currents to about the same as the x10 gain. At all gains, the error increases as the input current decreases.

### Comments

The AO pin on the X3100 is biased to a nominal 2.5V when reading the voltage across the VCS1 and VCS2 pins. However, there is an offset to this value that can make the output (at 0V input) either higher or lower than this 2.5V nominal value. The output with 0V current sense input ranged from 1.8 to 2.9V for the devices under test (at a gain of 160). The difference in voltage between the nominal output and the actual output becomes more apparent at higher gains. This is due to a small input offset in the current sense amplifier that is magnified at the output by the gain of the amplifier. This offset is mostly cancelled by reading the voltage across the CSI pins in both directions and subtracting the two values.

While the process of reading the voltage in both directions and subtracting the two values cancels most of the offset on the X3100 current sense amplifier, it does not cancel it all. The remaining output offset is approximately 668uV at a gain of 10, 1.7mV at a gain of 25, 5.7mV at a gain of 80 and 11mV at a gain of 160. This offset becomes significant at the lowest input voltages, since it can be nearly the same voltage as the expected output. In some of the charts that follow, the output has been compensated by subtracting this offset from the recorded values. This cancels out the error for average conditions, but leaves large errors at small input voltages due to variations in this offset. With the test setup used it is not possible to determine whether these offset error variations are caused by the environment or the device.

The charts in this document that show errors after offset compensation use an average offset value. This value is an average over all devices across all temperatures. To improve the accuracy, especially at lower input voltages, a calibration procedure could be used. This calibration procedure would apply 0V across the VCS1 and VCS2 pins. Then, at each gain setting, the measured output (after reading in both directions and subtracting) is saved as a common offset value.

The gain adjust is determined by dividing the output by the input voltage. The gain is averaged over all inputs and all devices at all temperatures. This average value is then used to divide into the output reading to determine the compensated error. Based on the data collected, the average gain for the 160 setting is 160.17, the average gain for the 80 setting is 79.24, the average gain for the 25 setting is 24.53 and the average gain for the 10 setting is 9.77. Using these average values will reduce the error when computing the input current. However to improve the accuracy further, each device can be calibrated for the particular gain. To do this, apply a known current across the current sense resistor. Use a current that is relatively high, such as 500mA. At each gain read the output and divide this by the known input. Use this gain value in subsequent calculations.

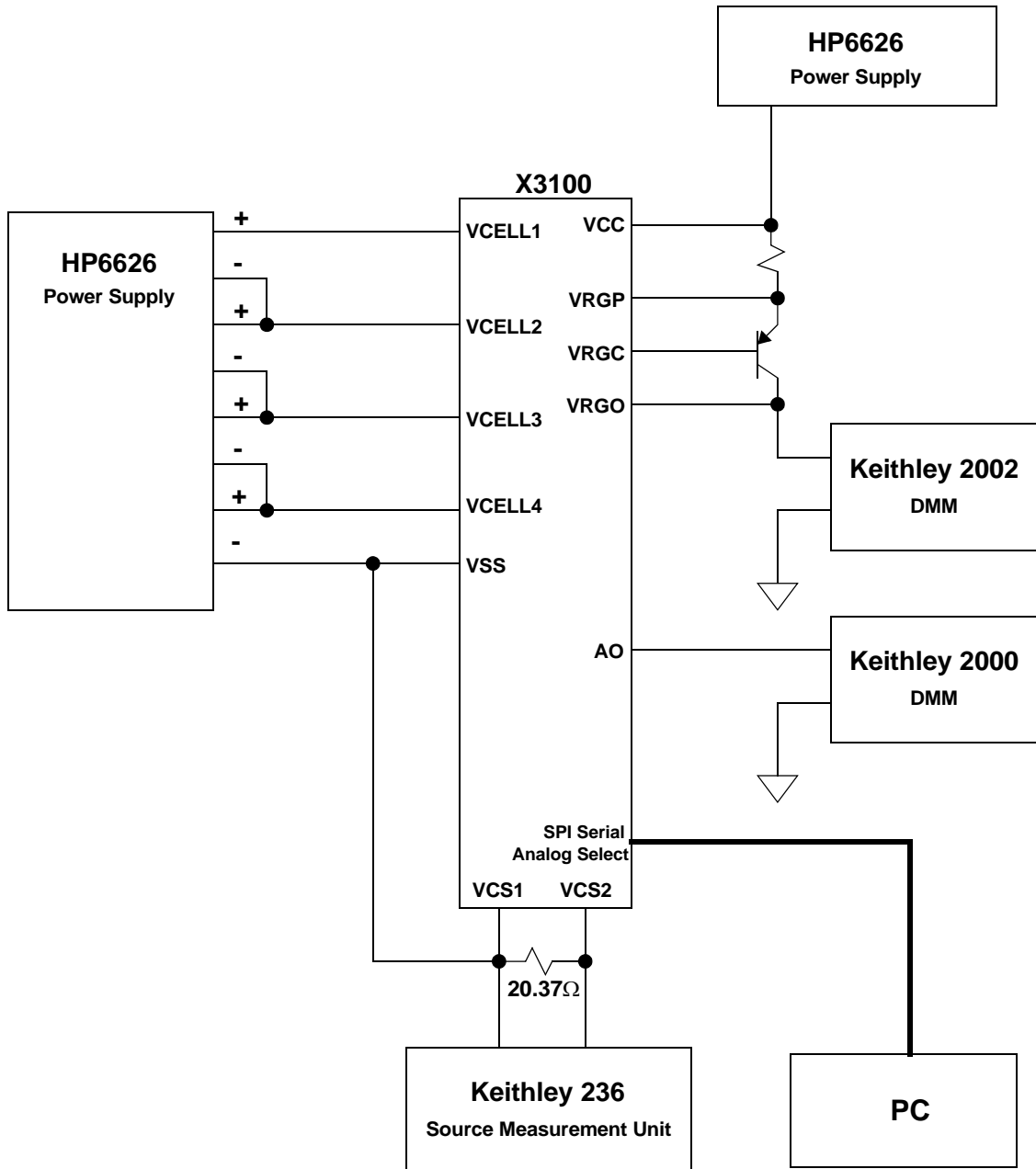

FIGURE 2. CHARACTERIZATION TEST SETUP

10 Gain

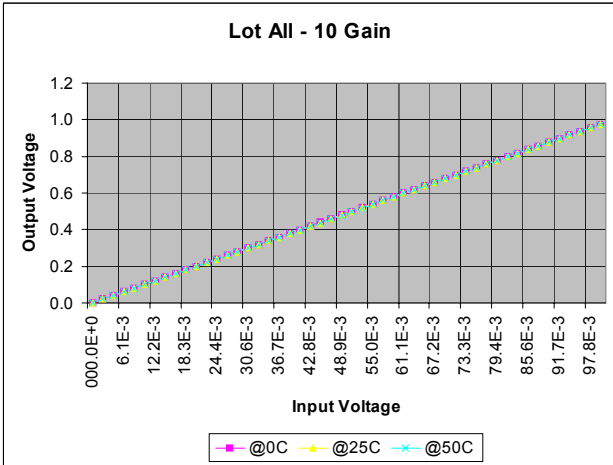

FIGURE 3. INPUT TO OUTPUT VOLTAGE

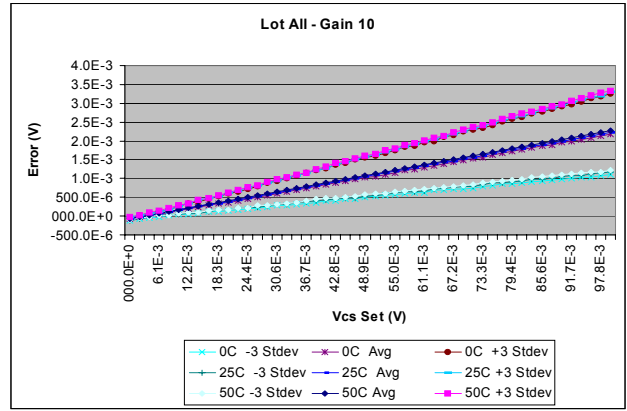

FIGURE 4. INPUT TO OUTPUT ERROR. THIS IS THE RAW ERROR WITH NO CORRECTION FOR OFFSET OR GAIN. IT INCLUDES ERROR AT EACH TEMPERATURE WITH THREE STANDARD DEVIATIONS

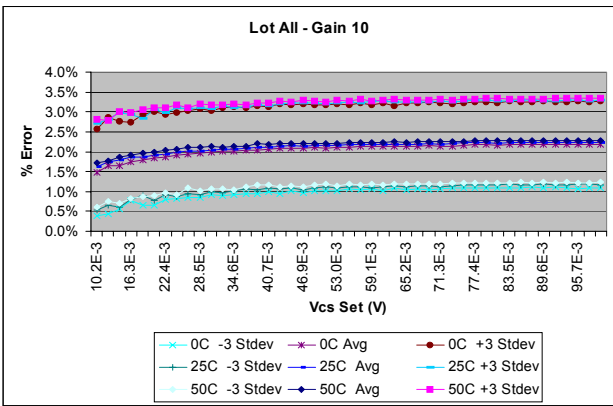

FIGURE 5. INPUT TO OUTPUT % ERROR (EXPANDED - STARTS AT 10mV INPUT). THIS IS THE RAW ERROR WITH NO CORRECTION FOR OFFSET OR GAIN. IT INCLUDES ERROR AT EACH TEMPERATURE WITH THREE STANDARD DEVIATIONS

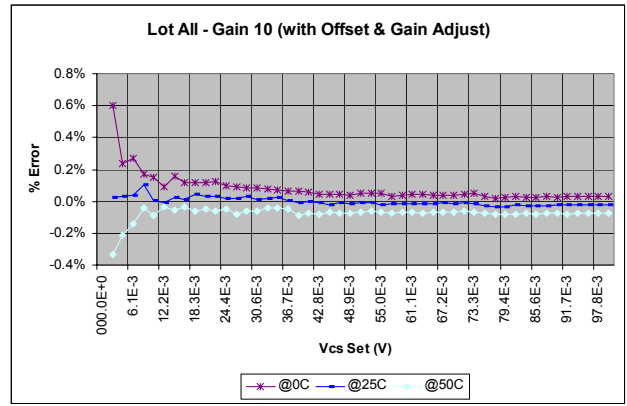

FIGURE 6. AVERAGE INPUT TO OUTPUT ERROR WITH CORRECTION FOR OFFSET AND GAIN FOR EACH INPUT VOLTAGE AT 0°C, 25°C AND 50°C

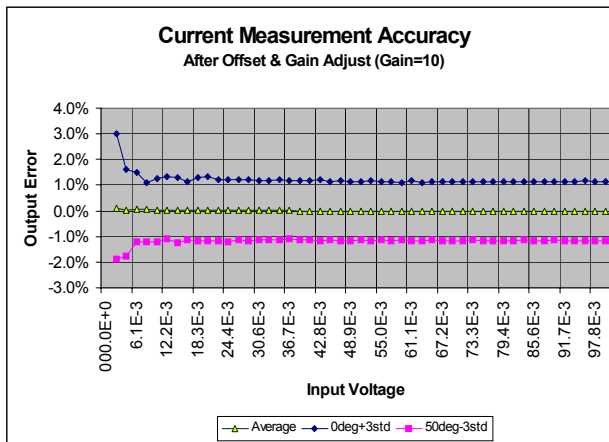

FIGURE 7. WORST CASE INPUT TO OUTPUT ERROR WITH CORRECTION FOR OFFSET AND GAIN. THE TERM +3 STDEV IS THE WORST CASE VALUE FOR 0°C. THE TERM -3 STDEV IS THE WORST CASE VALUE FOR 50°C

25 Gain

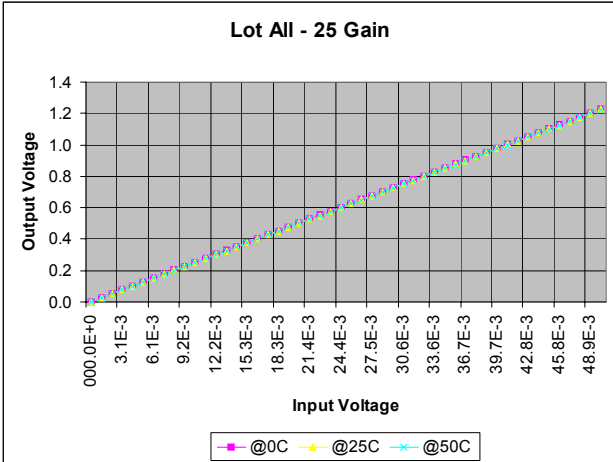

FIGURE 8. INPUT TO OUTPUT VOLTAGE

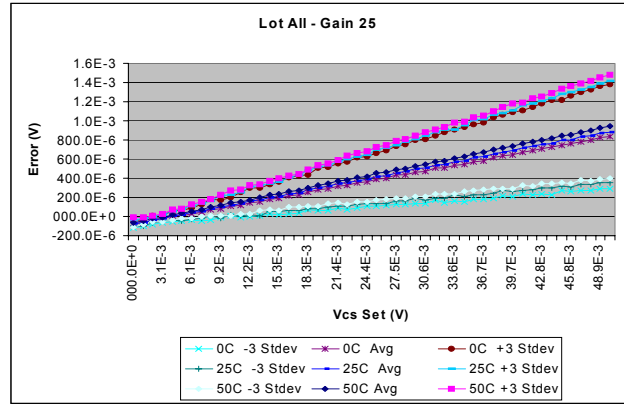

FIGURE 9. INPUT TO OUTPUT ERROR. THIS IS THE RAW ERROR WITH NO CORRECTION FOR OFFSET OR GAIN. IT INCLUDES ERROR AT EACH TEMPERATURE WITH THREE STANDARD DEVIATIONS

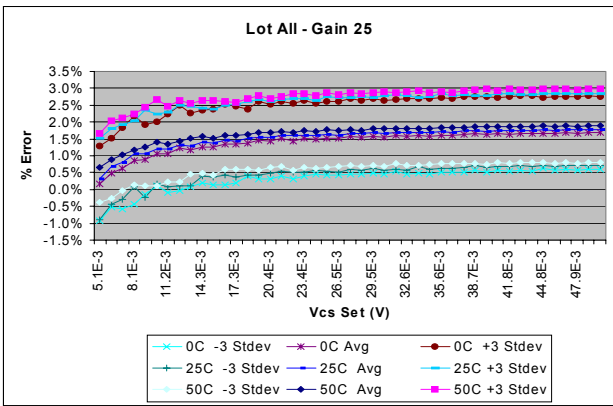

FIGURE 10. INPUT TO OUTPUT % ERROR (EXPANDED - STARTS AT 5mV INPUT). THIS IS THE RAW ERROR WITH NO CORRECTION FOR OFFSET OR GAIN. IT INCLUDES ERROR AT EACH TEMPERATURE WITH THREE STANDARD DEVIATIONS

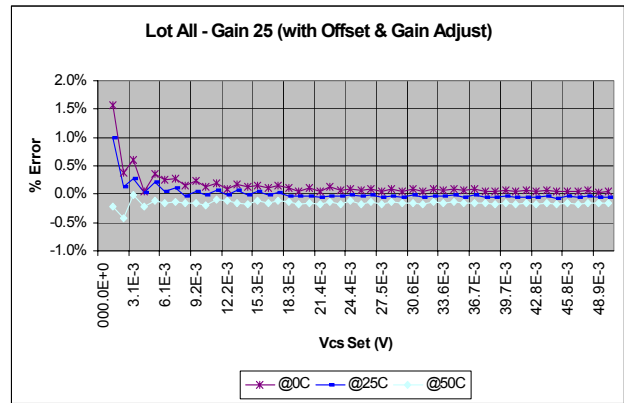

FIGURE 11. AVERAGE INPUT TO OUTPUT ERROR WITH CORRECTION FOR OFFSET AND GAIN FOR EACH INPUT VOLTAGE AT 0°C, 25°C AND 50°C

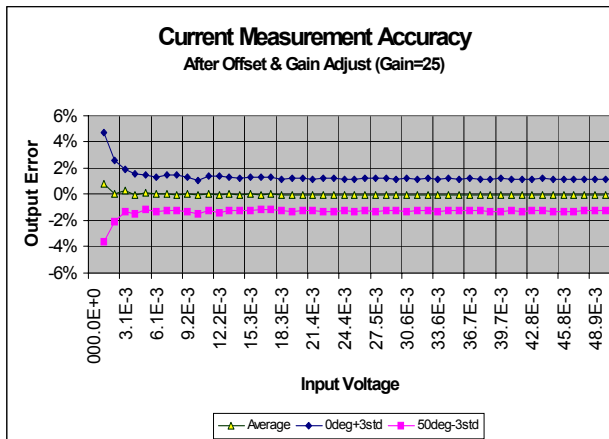

FIGURE 12. WORST CASE INPUT TO OUTPUT ERROR WITH CORRECTION FOR OFFSET AND GAIN. THE TERM +3 STDEV IS WORST CASE VALUE FOR 0°C. THE TERM -3 STDEV IS THE WORST CASE VALUE FOR 50°C

80 Gain

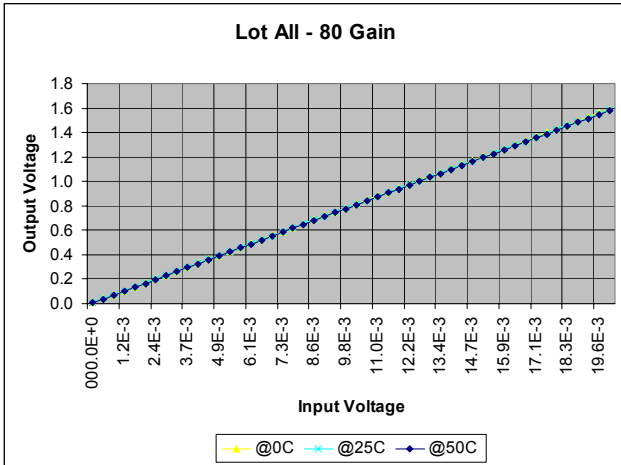

FIGURE 13. INPUT TO OUTPUT VOLTAGE

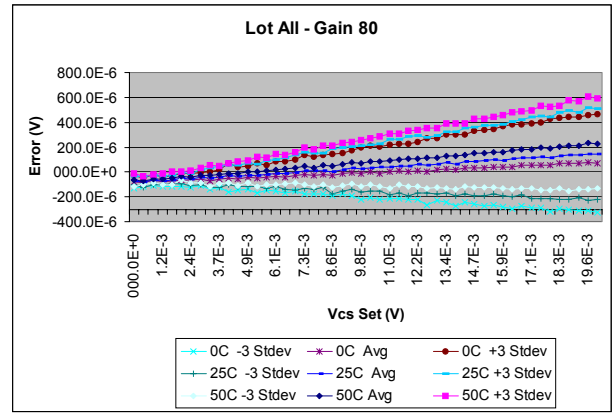

FIGURE 14. INPUT TO OUTPUT ERROR. THIS IS THE RAW ERROR WITH NO CORRECTION FOR OFFSET OR GAIN. IT INCLUDES ERROR AT EACH TEMPERATURE WITH THREE STANDARD DEVIATIONS

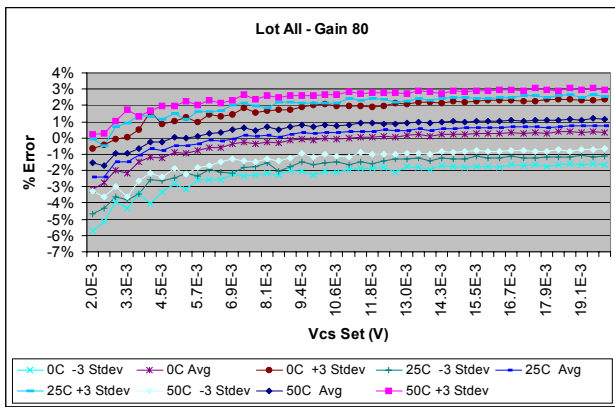

FIGURE 15. INPUT TO OUTPUT % ERROR (EXPANDED - STARTS AT 2mV INPUT). THIS IS THE RAW ERROR WITH NO CORRECTION FOR OFFSET OR GAIN. IT INCLUDES ERROR AT EACH TEMPERATURE WITH THREE STANDARD DEVIATIONS

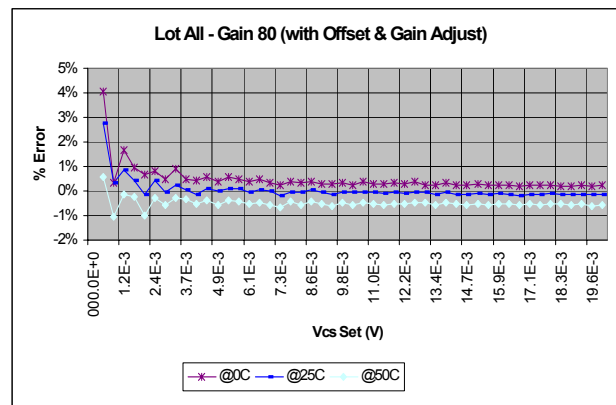

FIGURE 16. AVERAGE INPUT TO OUTPUT ERROR WITH CORRECTION FOR OFFSET AND GAIN FOR EACH INPUT VOLTAGE AT 0°C, 25°C AND 50°C

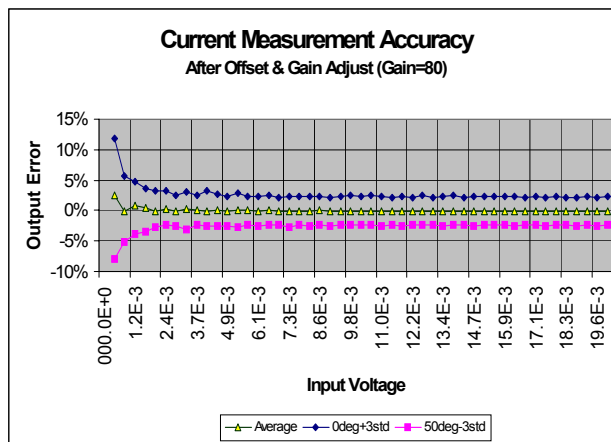

FIGURE 17. WORST CASE INPUT TO OUTPUT ERROR WITH CORRECTION FOR OFFSET AND GAIN. THE TERM +3 STDEV IS WORST CASE VALUE FOR 0°C. THE TERM -3 STDEV IS THE WORST CASE VALUE FOR 50°C

160 Gain

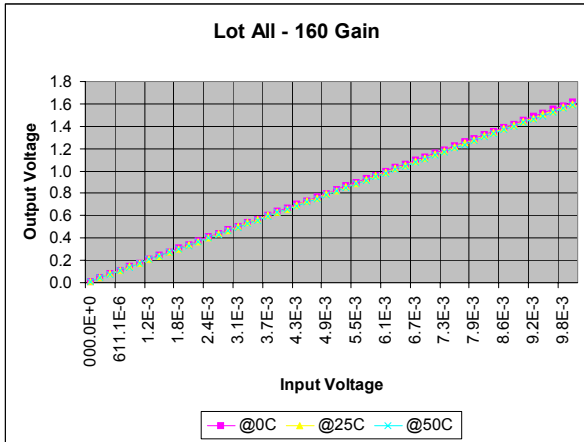

FIGURE 18. INPUT TO OUTPUT VOLTAGE

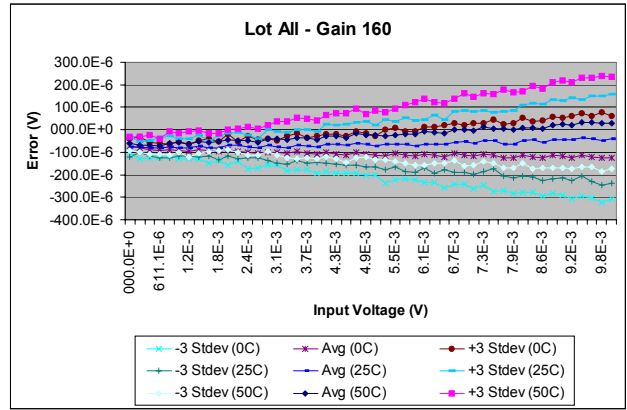

FIGURE 19. INPUT TO OUTPUT ERROR. THIS IS THE RAW ERROR WITH NO CORRECTION FOR OFFSET OR GAIN. IT INCLUDES ERROR AT EACH TEMPERATURE WITH THREE STANDARD DEVIATIONS

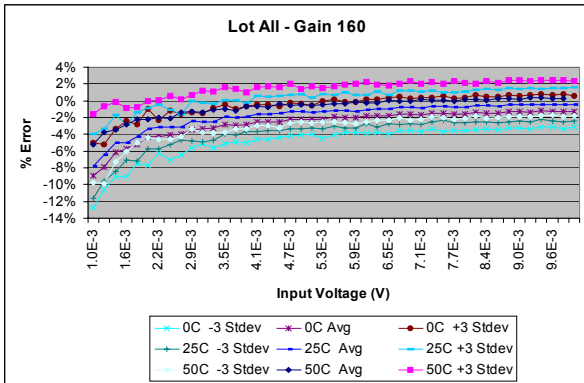

FIGURE 20. INPUT TO OUTPUT % ERROR (EXPANDED - STARTS AT 1mV INPUT). THIS IS THE RAW ERROR WITH NO CORRECTION FOR OFFSET OR GAIN. IT INCLUDES ERROR AT EACH TEMPERATURE WITH THREE STANDARD DEVIATIONS

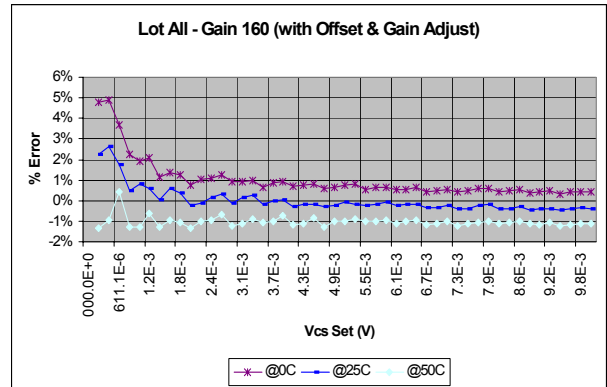

FIGURE 21. AVERAGE INPUT TO OUTPUT ERROR WITH CORRECTION FOR OFFSET AND GAIN FOR EACH INPUT VOLTAGE AT 0°C, 25°C AND 50°C

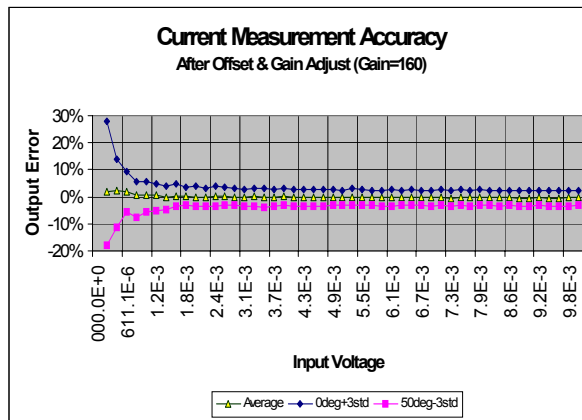

FIGURE 22. WORST CASE INPUT TO OUTPUT ERROR WITH CORRECTION FOR OFFSET AND GAIN. THE TERM +3 STDEV IS WORST CASE VALUE FOR 0°C. THE TERM -3 STDEV IS THE WORST CASE VALUE FOR 50°C

Intersil Corporation reserves the right to make changes in circuit design, software and/or specifications at any time without notice. Accordingly, the reader is cautioned to verify that the Application Note or Technical Brief is current before proceeding.

For information regarding Intersil Corporation and its products, see [www.intersil.com](http://www.intersil.com)